

**6" BARRIER CURB & GUTTER**

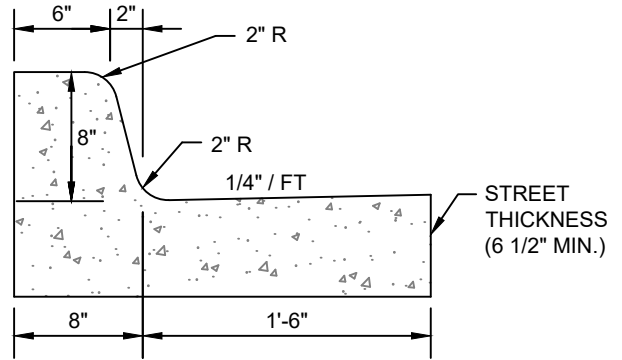

**8" BARRIER CURB & GUTTER**

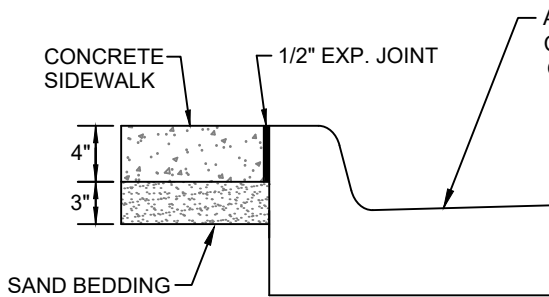

**SIDEWALK ADJACENT TO CURB**

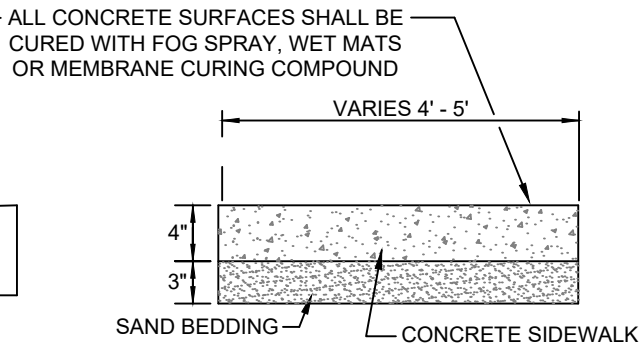

**SIDEWALK DETAIL**

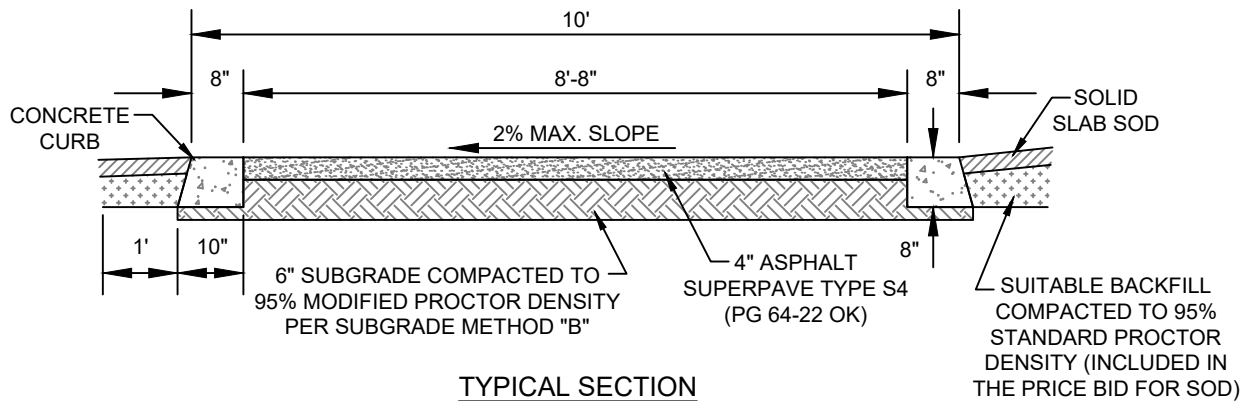

**TYPICAL SECTION  
10' WIDE PEDESTRIAN TRAIL**

**NOTES:**

1. #6 x 24" DOWELS AT 24"-30" MAX. C/C REQUIRED WHEN PAVEMENT SECTION IS NOT PLACED INTEGRALLY WITH CURB AND GUTTER.
2. FOR ASPHALTIC CONCRETE PAVEMENTS, SAW CUT CURB AND GUTTER JOINTS 10'-15' MAX. C/C WITH EVERY 8TH JOINT A 3/4" EXPANSION JOINT. FOR CONCRETE PAVEMENTS, CURB JOINT SHALL MATCH PAVEMENT JOINTS.
3. CONCRETE SHALL BE 4,000 PSI (ODOT CLASS AA).
4. EXPANSION JOINTS ARE REQUIRED AT INTERSECTIONS WITH STORMWATER INLET BOXES.

REVISION	BY	DATE	<b>CURB &amp; GUTTER, SIDEWALK, AND TRAIL</b>	
			STANDARD DETAILS	
			CITY OF JENKS, OKLAHOMA	
			ENGINEERING DEPARTMENT	
			DATE: 4-11-22	STANDARD NO. STRT-06