



CITY OF JENKS
211 NORTH ELM STREET • P.O. BOX 2007
JENKS, OKLAHOMA 74037-2007
PHONE (918) 299-5883

May 24, 2022

RE: Water Service Connections

Water service connections in the City of Jenks are to be installed by contractors and plumbers, rather than by city personnel. Contractors/plumbers must meet specific qualifications to be included on an approved list that is maintained by the City. Builders are required to select a firm from the list of contractors/plumbers that is available at City Hall – Revenue Collections Office.

All materials needed for water services (with the exception of the water meter) are to be supplied and installed by the builder or their contractor/plumber. This process enables builders to have more effective control over the timing of meter installations during construction. In order to monitor installations and inspections, the City will provide the water meter after Public Works Department personnel have inspected the installation for conformance with specifications.

Your company must be registered with the City of Jenks prior to being included on the approved list for water service connections. Registration can be done at the Revenue Collections Office by providing your contractor's license and payment of the current registration fee.

To be included on the approved list of contractors/plumbers for water service installations in the City of Jenks, the following items must be submitted:

1. A completed "Application for Water Service Installation Contractor" (included in the attached Procedures).
2. Proof of Liability Insurance coverage in the amounts indicated in the Procedures. The City of Jenks/Jenks Public Works Authority shall be named as "Additional Insured" along with the certificate holder.
3. Evidence of similar work performed in the last two (2) years. Submit a list of projects, project locations and short description of the type of work performed.
4. Submittal of four (4) professional or business references (including current contact name, address and telephone number).

To ensure your firm is included on the approved list, return the attached application with supporting documentation to this office. The list is updated annually; therefore, you will receive a letter and renewal form prior to the June 30 expiration date each year. The renewal form and Proof of Liability Insurance must be processed prior to the expiration date.

After the application is approved, a copy will be returned to you. If you have any questions, contact this office at 918.299.5883.

CITY OF JENKS

Tanner Rush
Development Coordinator

**CITY OF JENKS
JENKS PUBLIC WORKS AUTHORITY**

**PROCEDURES
FOR
WATER METER INSTALLATIONS BY CONTRACTOR**

A. WATER METER INSTALLATION BY CONTRACTOR PROCEDURE

The following is a general chronology of the procedure for water meter installation by approved plumbers and/or contractors (hereinafter referred to as "Contractor"):

1. Contractor desiring to be included on approved list submits application and required documents to City of Jenks.
2. Upon meeting defined qualifications, contractor is included on approved list.
3. Owner/Builder selects contractor from approved list.
4. Owner/Builder or contractor makes application for service and pays applicable fees to the City of Jenks.
5. Contractor installs service. The installation is to be left uncovered for inspection, but safety considerations dictate that any excavation should be covered at the end of the day.
 - a. No inspections will be performed on Saturday, Sunday or City of Jenks holidays.
 - b. The last call-in time requesting an inspection is 3:30pm.
 - c. Allow at least one (1) hour for an inspector to arrive at the site.
6. City personnel inspect service for conformance with established materials and construction standards of the City of Jenks.
7. Upon successful inspection, City installs water meter.
8. One (1) year maintenance period starts upon installation of the water meter.

B. APPLICATION AND LIST OF APPROVED PLUMBERS AND CONTRACTORS

1. A listing of approved contractors will be established by the City of Jenks/Jenks Public Works Authority.
2. An "Application for Water Service Installation Contractor" (attached) shall be submitted along with the required documents for consideration by City of Jenks staff.
3. At a minimum, the list will be updated annually on or about July 1, but may be modified as contractors meeting the defined qualifications are approved or as contractors are removed for failure to meet the established performance criteria.
4. Only approved contractors included on the list will be allowed to perform water meter installations within the city limits.

C. QUALIFICATION CRITERIA

The following items are required to be provided for contractor qualifications:

1. Contractors are required to submit proof of continuous Liability Insurance coverage in the amounts of:
 - a. General Liability

Each occurrence	\$1,000,000
Damage to rented premises	\$100,000
Medical expenses (any one person)	\$5,000
Personal and adv injury	\$1,000,000
General aggregate	\$2,000,000
Products – comp/op aggregate	\$2,000,000
 - b. Automobile Liability

Combine single limit (each accident)	\$1,000,000
--------------------------------------	-------------
 - c. Workers Compensation Employer's Liability

Each accident	\$100,000
Disease (each employee)	\$100,000
Disease (policy limit)	\$500,000

The City of Jenks/Jenks Public Works Authority shall be named as “Additional Insured along with the certificate holder.

The cancellation notice shall be modified to state:

Should any of the above described policies be cancelled before the expiration date thereof; the issuing insurer will ~~endeavor to mail 30 days written notice to the certificate holder and additional insured named to the left, but failure to mail such notice shall impose no obligation or liability of any kind upon the insured, its agents or representatives.~~

Evidence of coverage is required to be submitted yearly with the application renewal or upon any change.

2. Evidence of similar work performed in the last 2 years. Submit a list of projects, project locations and short description of the type of work performed.
3. Submittal of four (4) professional or business references (including current contact name, address and telephone number).
4. Contractors are to be registered within the City of Jenks.

D. MATERIAL AND CONSTRUCTION STANDARDS

1. All materials used shall conform to City of Jenks standards (see Attachment 2).
2. Contractors shall be responsible for providing all required materials necessary for the water meter installation (with the exception of the water meter).
3. The City of Jenks will provide and install the water meter. Each contractor-installed water service will be inspected for conformance with the established standards prior to installation of the water meter by the city.
4. Failure of the contractor to perform the installation in conformance with city standards may result in the contractor being removed from the most current approved list.

E. INSTALLATION PROCESS

1. If damage to any city facilities occurs during the tap or meter installation, repairs are expected to be performed by the contractor. Contractor personnel are expected to remain at the site to perform the needed repairs or assist city crews as requested.
2. The contractor shall immediately inform the city that damage has occurred.
3. Only city personnel are authorized to operate main line valves in the event that the water supply needs to be controlled.
4. The city will inspect repairs to ensure conformance with established standards.
5. Under unusual circumstances, the contractor may need to defer repair to the city. Costs of materials, equipment, manpower, overhead used by the city and lost water will be invoiced to the contractor for compensation. Failure to submit payment for the invoiced amount within 15-days will result in the contractor being removed from the approved list.
6. The contractor is responsible to install crossing PVC casings which have not been installed or are not in the location needed.

F. WARRANTY OF WORK

1. Each water service shall be warranted for a period of one (1) year from the date of installation.
2. A contact person for the company shall be available and on 24-hour call should any repairs be necessary. Contact information must be current at all times and changes/additions shall be reported immediately to the city.
3. Upon notification by the city, warranty repair work is expected to be started within four (4) hours.
4. Under unusual circumstances that will not allow the contractor to respond in the required time period, the contractor may need to defer repair to the city. Costs of materials, equipment, manpower, overhead used by the city and lost water will be invoiced to the contractor for compensation. Failure to submit payment for the invoiced amount within 15-days will result in the contractor being removed from the approved list.

G. INSTALLATIONS BY THE CITY OF JENKS

1. Ordinance 1146 contains provisions for water meter installations by contractors and City of Jenks personnel. Owners are encouraged to use an approved contractor and to explore all other opportunities prior to contacting the City. A portion of the ordinance is extracted below:

§18-1-6. Fees for water service connection.

(A) Any person, firm or corporation desiring water service from the City of Jenks and having made application for such service at the Jenks Revenue Collections Office, shall pay to the City of Jenks the meter setting and connection or tap fee hereinafter set forth.

1. Contractor installed meter

All components (with the exception of the water meter), would be supplied and installed by a contractor on an approved list by the City of Jenks.

¾-inch meter	\$460.00
1-inch meter	\$515.00
2-inch meter	\$1,000.00

2. City installed meter

At times, the builder may not be able to utilize an approved plumber or contractor to install the meter. In these situations, the city may provide the entire installation.

¾-inch meter	\$835.00
1-inch meter	\$1,150.00
2-inch meter	\$2,610.00

(*plus cost of road bores and extra materials and labor for cross-street connections)

3. Connections in excess of 2-inches shall be determined on a case-by-case basis.

2. Installations by the City of Jenks personnel will be considered based only on the following criteria:
 - Only 3/4-inch, 1-inch or 2-inch meters will be installed.
 - Owners must document they have explored using all approved contractors prior to contacting the City.
 - No other meter installations are scheduled for installation by the City.
 - A minimum of 5 working days notice is required to complete the installation.
 - No cross-street boring is required.
 - Based on projected workloads, sufficient City personnel/equipment is available.

H. HOLD HARMLESS AND INDEMNIFICATION

The Contractor shall hold the City of Jenks, the Jenks Public Works Authority, their officers, agents and employees harmless and indemnify them from any claims resulting from the Contractor's actions.

I. ATTACHMENTS

- Application for Water Service Installation Contractor
- Water Meter Materials Specifications/Construction Details (3/4-inch, 1-inch and 2-inch)



City of Jenks / Jenks Public Works Authority

Application for Water Service Installation Contractor

PRINT OR TYPE

DATE SUBMITTED: _____

PERMIT NUMBER:

CONTRACTOR NAME: _____

CONTRACTOR ADDRESS: _____

EMAIL: _____

TELEPHONE NUMBER: _____

24-HOUR POINT OF CONTACT INFORMATION

Contact Name: _____

PRINT

Principle Telephone Number: _____

Alternate Telephone Number: _____

By signing this application, the Contractor acknowledges that he/she has reviewed and is familiar with the "Procedures - Water Meter Installations by the Contractor". The Contractor agrees to hold the City of Jenks, the Jenks Public Works Authority, their officers, agents and employees harmless and indemnify them from any claims resulting from the Contractor's actions.

Signed By: _____

PRINT NAME

FOR CITY USE

Required documents to be submitted for qualification:

- Proof of Liability Insurance Coverage
- Evidence of similar work performed in the last 2 years
- Submittal of four (4) references

Comments

Date Approved: _____

Approved By: _____

Renewal Date: _____

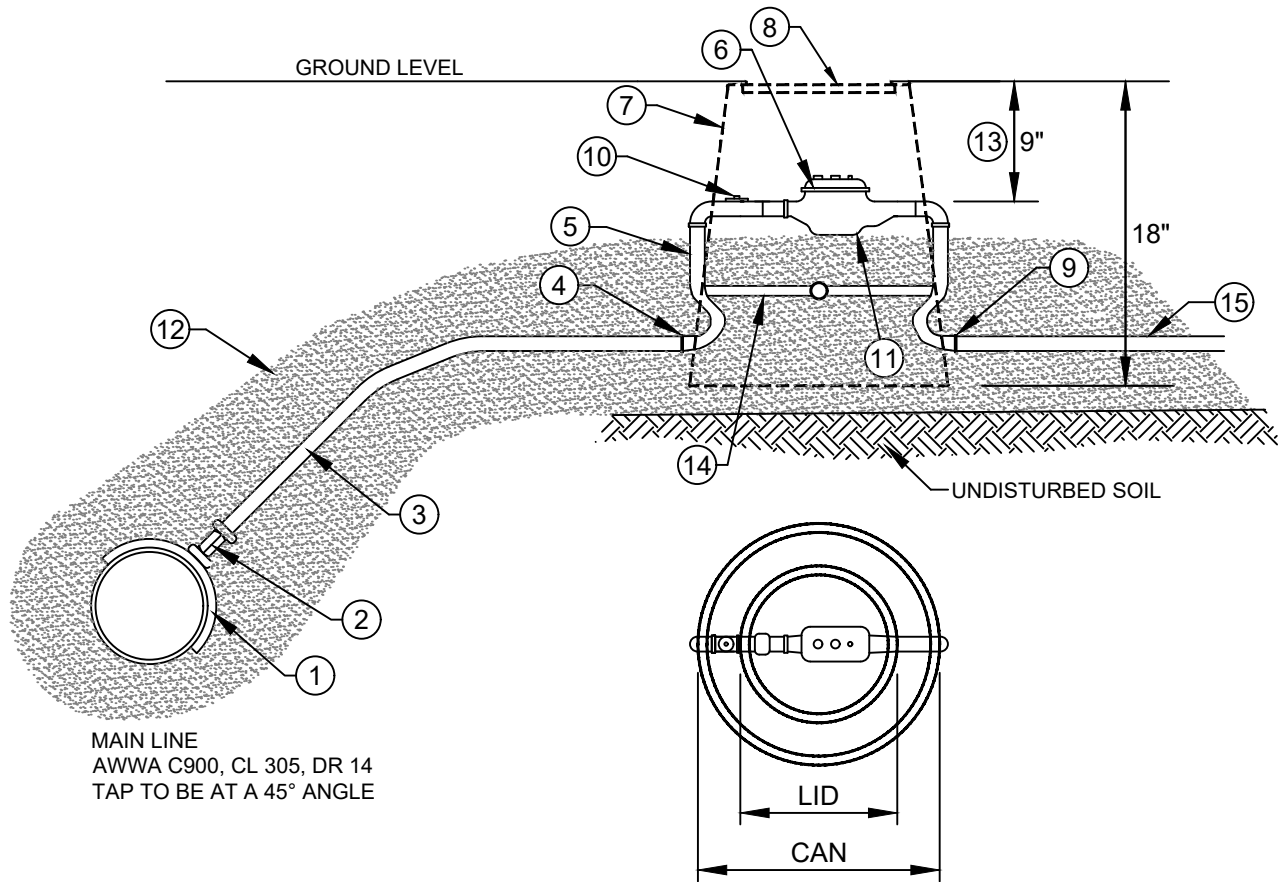

3/4" & 1" TAP MATERIALS LIST

1. TAPPING SADDLE: 3/4" OR 1" - FORD OR SMITH-BLAIR, MODEL 315, SINGLE BAND, IP THREAD, OR MUELLER DR1S MODEL, SS SINGLE BAND IP THREAD.*
2. CORPORATION STOP:
3/4" - FORD, MODEL #F1100-3-NL, IP THREAD x CTS COMPRESSION FITTING, OR MUELLER 3/4" P15028N.**
1" - FORD, MODEL #F1100-4-NL, IP THREAD x CTS COMPRESSION FITTING, OR MUELLER 1" P15028N.**
3. SERVICE LINE: 3/4" OR 1" - TUFF-TUBE, BLUE.
4. COMPRESSION FITTING: 3/4" OR 1" - CTS WITH STIFFENER INSERTS.
5. METER SETTER: 3/4" OR 1" - FORD OR MUELLER BRASS/COPPER, CTS x FEMALE IP OR CTS x CTS.
6. METER: 3/4" OR 1" - PROVIDED BY THE CITY OF JENKS.
7. METER CAN:
3/4" - BROOKS, B2200.
1" - BROOKS, 1220-12.
8. METER CAN LID:
3/4" - BROOKS, CAST IRON LID W/SITE HOLE TOUCH READ.
1" - BROOKS, 1220-CT LID.
9. FITTING: 3/4" OR 1" - CTS x CTS
10. 3/4" OR 1" - METER SHUT OFF VALVE.
11. 3/4" OR 1" - METER FREEZE PLATE.
12. 3/4" OR 1" - CLEAN RIVER/FILL SAND.
13. 3/4" OR 1" - METER SETTER SHALL BE 9" BELOW LID (FINAL GRADE).
14. STABILIZATION BAR.
15. CUSTOMER SERVICE LINE.

* RANGE SHALL BE FOR C900 OR DR21 PVC PIPE.

** INSTALL CORPORATION STOP SO OPERATING LEVER IS OVER CENTERLINE OF MAIN.

REVISION	BY	DATE	3/4" & 1" METER SETTING	
			STANDARD DETAILS	
			CITY OF JENKS, OKLAHOMA	
			ENGINEERING DEPARTMENT	
			DATE: 4-11-22	STANDARD NO. WAT-08

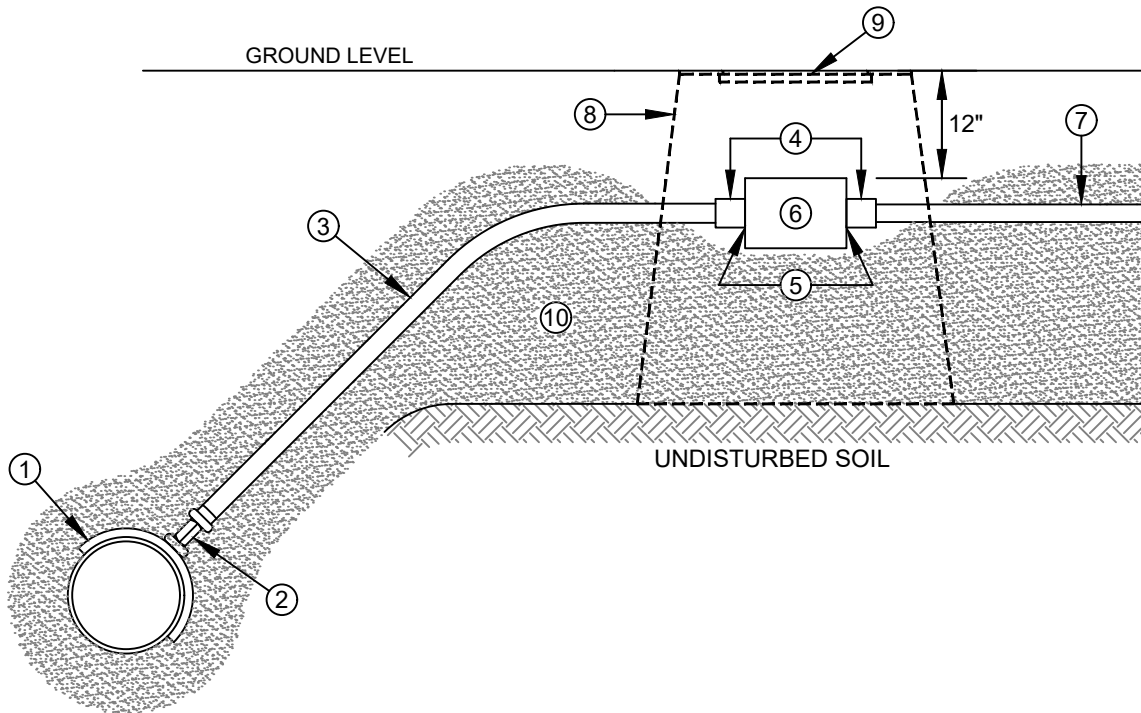

MAIN LINE
 AWWA C900, CL 305, DR 14
 TAP TO BE AT TOP OF PIPE

2" TAP MATERIALS LIST

1. TAPPING SADDLE: FORD OR SMITH-BLAIR, MODEL 315, SINGLE BAND, IP THREAD.*
2. CORPORATION STOP: FORD, MODEL #F500-7-NL, IP THREAD x CTS COMPRESSION FITTING.**
3. SERVICE LINE: 2" SCH 80 PVC OR 2" TUFF-TUBE, BLUE.
4. 2" BALL VALVE: FORD, 1/4 TURN W/MALE IP x FLANGE FITTING W/STAINLESS STEEL BOLTS.
5. RUBBER GASKET BETWEEN BALL VALVE AND METER.
6. 2" METER TO BE PROVIDED BY THE CITY OF JENKS AND INSTALLED BY CONTRACTOR.
7. CUSTOMER SERVICE: 2" SCH 80 PVC OR 2" TUFF-TUBE, BLUE, CONNECTED BY CONTRACTOR.
8. METER CAN: BROOKS, MODEL #173018.
9. METER LID: BROOKS, MODEL #1730 W/FLASH COVER.
10. CLEAN RIVER/FILL SAND.

* RANGE SHALL BE FOR C900 OR DR21 PVC PIPE.

** INSTALL CORPORATION STOP SO OPERATING LEVER IS OVER CENTERLINE OF MAIN.

REVISION	BY	DATE	2" METER SETTING	
			STANDARD DETAILS	
			CITY OF JENKS, OKLAHOMA	
			ENGINEERING DEPARTMENT	
			DATE: 4-11-22	STANDARD NO. WAT-09

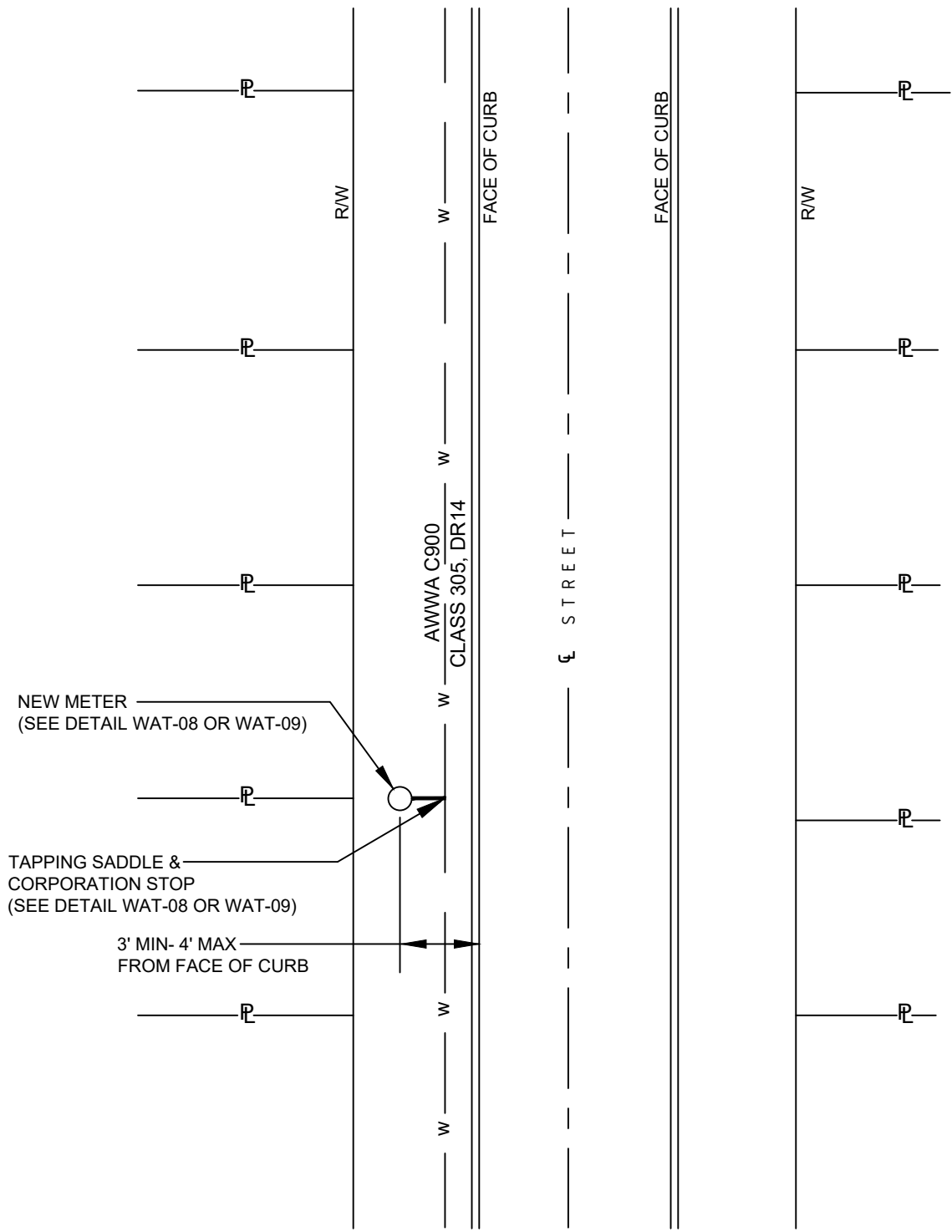

NOTE:

SHORT WATER SERVICE SHALL BE LOCATED AT A SIDE LOT LINE.

REVISION	BY	DATE	SHORT WATER SERVICE STANDARD DETAILS	
			ENGINEERING DEPARTMENT	
			DATE: 4-11-22	STANDARD NO. WAT-10

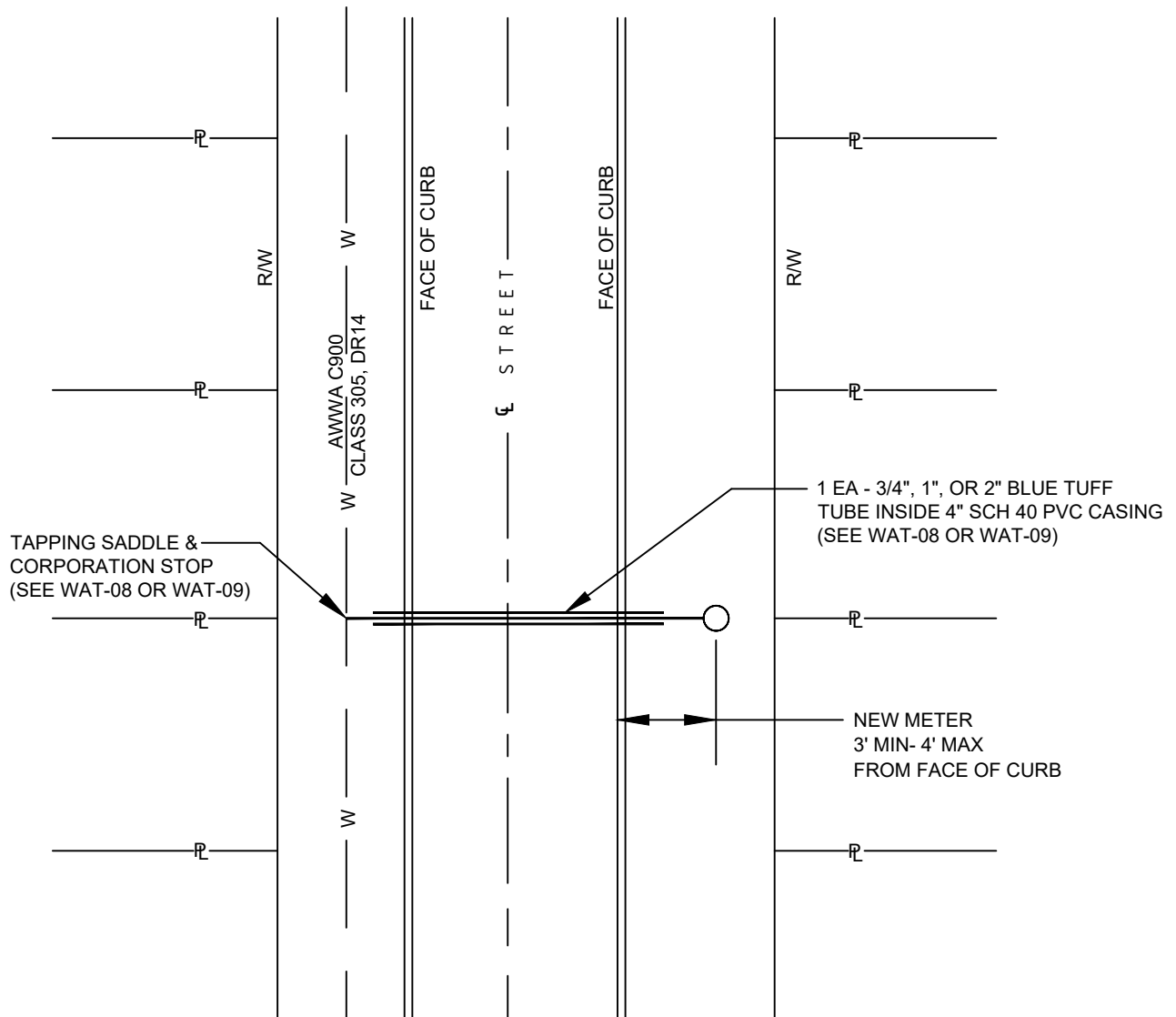

NOTES:

1. LONG WATER SERVICE CROSSINGS SHALL RUN FROM THE SIDE LOT LINE ON ONE SIDE OF THE STREET TO A SIDE LOT LINE ON THE OTHER SIDE OF THE STREET.
2. 4" SCH 40 PVC CONDUIT SHALL EXTEND 2' MINIMUM BEHIND FACE OF CURB.
3. BACKFILL TRENCH, FROM TOP OF CONDUIT TO STREET SUBGRADE, WITH CEMENTUOUS FLOWABLE FILL.
4. SERVICE LINE SHALL BE BORED IF PVMT. EXISTS.

REVISION	BY	DATE	LONG WATER SERVICE (SINGLE)	
			STANDARD DETAILS	
			CITY OF JENKS, OKLAHOMA	
			ENGINEERING DEPARTMENT	
			DATE: 4-11-22	STANDARD NO. WAT-11

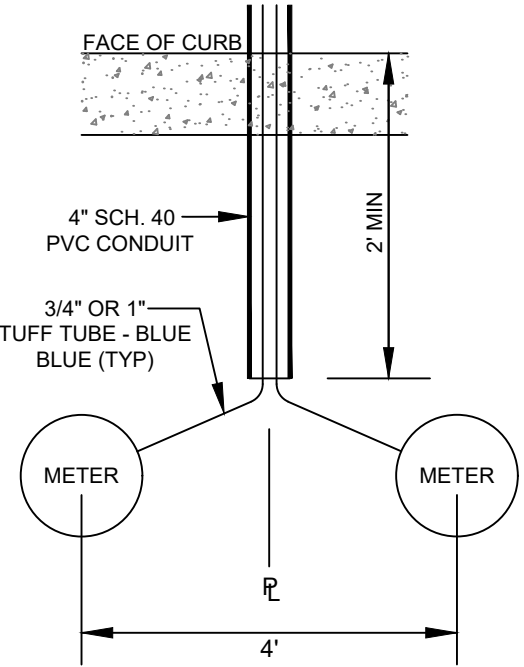
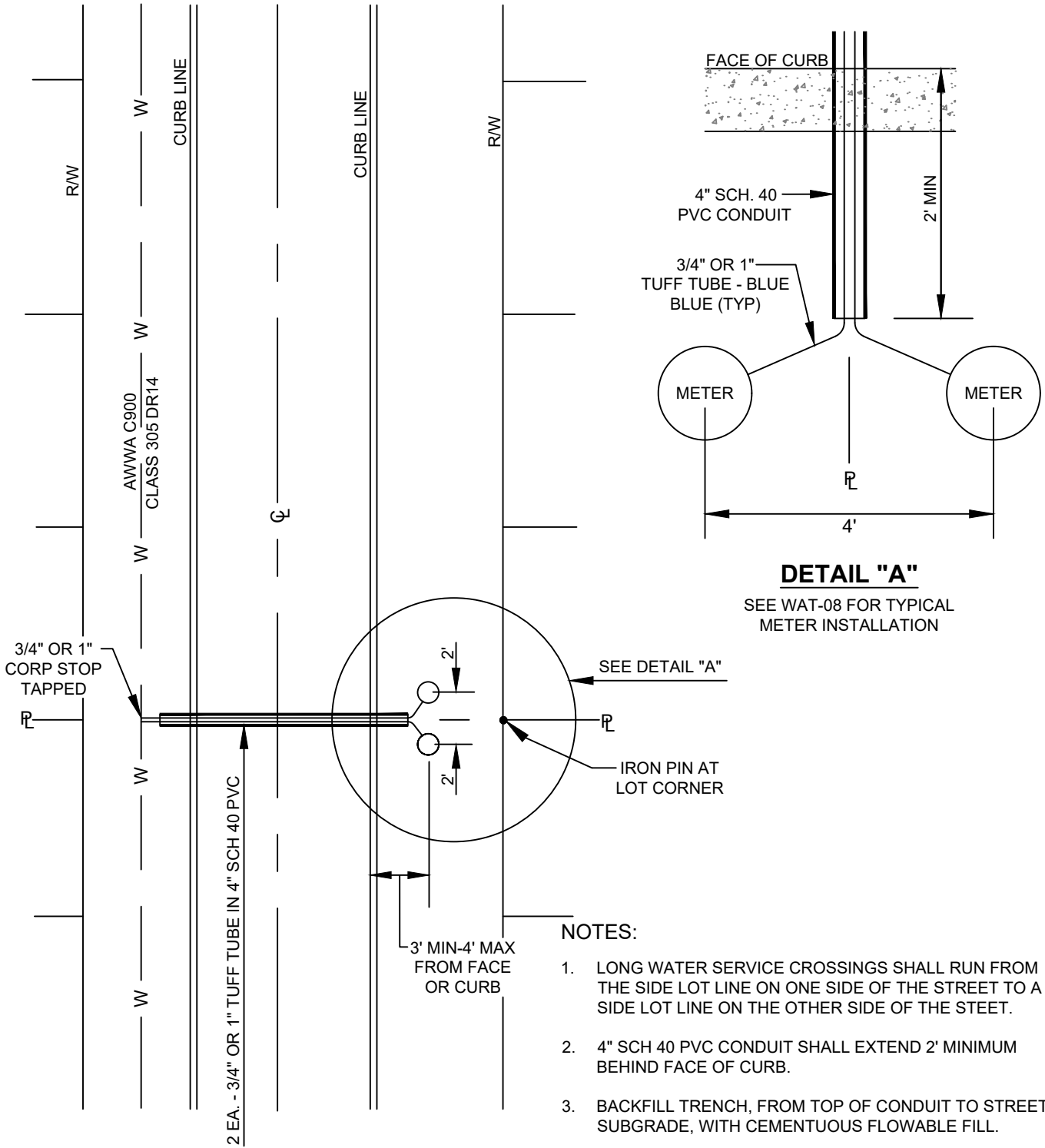

DETAIL "A"
SEE WAT-08 FOR TYPICAL
METER INSTALLATION

- NOTES:**
1. LONG WATER SERVICE CROSSINGS SHALL RUN FROM THE SIDE LOT LINE ON ONE SIDE OF THE STREET TO A SIDE LOT LINE ON THE OTHER SIDE OF THE STREET.
 2. 4" SCH 40 PVC CONDUIT SHALL EXTEND 2' MINIMUM BEHIND FACE OF CURB.
 3. BACKFILL TRENCH, FROM TOP OF CONDUIT TO STREET SUBGRADE, WITH CEMENTUOUS FLOWABLE FILL.
 4. SERVICE LINE SHALL BE BORED IF PAVEMENT EXISTS.

REVISION	BY	DATE	LONG WATER SERVICE (DOUBLE) STANDARD DETAILS	
			CITY OF JENKS, OKLAHOMA	
			ENGINEERING DEPARTMENT	
			DATE: 4-11-22	STANDARD NO. WAT-12